

# PHOTOVOLTAIC CONVERTER - BASICS AND BENEFITS

Tridibesh Das\* & Ashutosh Gain\*\*

\* Lecturer, Department of Mechanical Engineering

\*\* Visiting Lecturer, Department of Mechanical Engineering

## Abstract

Economics are crucial to the success of any energy utilization system, and photovoltaic converters are no exception. At present, development of such converters is in the stage in which prices are still coming down rapidly. It is nevertheless, difficult to compare photovoltaic with other systems solely on the basis of investment cost. While photovoltaic have low operating cost, since they consume no fuel, their peak power can be only realized on a clear day, with the converter facing the sun. The average power will be less than half the peak power for sun tracking systems and less than one fourth of the peak power for nontracking systems.

## Introduction

The broad-band solar spectrum can be split into slices of radiation whose frequencies match the properties of the semiconductors used in the photodiodes. Thus, for silicon, a narrow band beginning at 265 THz would best match its 1.1 eV band gap energy.

A silicon atom consists of a nucleus, containing 14 protons and 14 neutrons, surrounded by 14 electrons. The nucleus carries a charge of +14 but the atom has no net charge owing to the 14 electrons swarming around it.

Observe that 10 of the 14 electrons are tightly bound to the nucleus and are difficult to remove. However, four electrons (called valence electrons) can be easily removed (ionizing the atom) and are, therefore, able to take part in chemical reactions. Silicon is, consequently, tetravalent. It proves convenient to represent a silicon atom as consisting of a kernel surrounded by four valence electrons. The kernel, because it has fourteen positive charges from

the nucleus and ten tightly bound electrons, has a net charge of +4. The atom, as a whole, is, of course, neutral because the charge of the four valence electrons cancels that of the kernel.

Two silicon atoms can be bound one to another by exchanging valence electrons. Such a bond is called a covalent bond. Because it has four valence electrons, each silicon atom can make four covalent bonds attaching it to four neighboring atoms. However, if a bond is disrupted (by thermal agitation of the lattice or through the impact of a photon or a high speed free electron) then one of the valence electrons is ejected from the bond and becomes free to carry electricity, leaving behind an incomplete bond, one in which a hole exists into which an electron from a neighbouring bond can fall. This causes the hole to move to a new place. Thus the disruption of a bond creates a pair of carriers—an electron and a hole imparting some degree of conductivity to the material.

Semiconductor light detectors can be divided into two major categories: junction and bulk effect devices. Junction devices, when operated in the photoconductive mode, utilize the reverse characteristic of a PN junction. Under reverse bias, the PN junction acts as a light controlled current source. Output is proportional to incident illumination and is relatively independent of implied voltage as shown in Figure 1. Silicon photodiodes are examples of this type detector.

In contrast, bulk effect photoconductors have no junction. As shown in Figure 2, the bulk resistivity decreases with increasing illumination, allowing more photocurrent to flow. This resistive characteristic gives bulk effect photoconductors a unique quality: signal current from the detector can be varied over a wide range by adjusting the applied voltage. To clearly make

this distinction, PerkinElmer Optoelectronics refers to its bulk effect photoconductors as photoconductive cells or simply photocells. Photocells are thin film devices made by depositing a layer of a photoconductive material on a ceramic substrate. Metal contacts are evaporated over the surface of the photoconductor and external electrical connection is made to these contacts. These thin films of photoconductive material have a high sheet resistance. Therefore, the space between the two contacts is made narrow and interdigitated for low cell resistance at moderate light levels. This construction is shown in Figure 3.

### Why Use Photocells?

Photocells can provide a very economic and technically superior solution for many applications where the presence or absence of light is sensed (digital operation) or where the intensity of light needs to be measured (analog operation). Their general characteristics and features can be summarized as follows:

- *Lowest cost available, and near-IR photo detector*
- *Available in low cost plastic encapsulated packages as well as hermetic packages (TO-46, TO-5, TO-8)*
- *Responsive to both very low light levels (moonlight) and to very high light levels (direct sunlight)*
- *Wide dynamic range: resistance changes of several orders of magnitude between "light" and "no light"*
- *Low noise distortion*
- *Maximum operating voltages of 50 to 400 volts are suitable for operation on 120/240 VAC*
- *Available in center tap dual cell configurations as well as specially selected resistance ranges for special applications*
- *Easy to use in DC or AC circuits - they are a light variable resistor and hence symmetrical with respect to AC waveforms*
- *Usable with almost any visible or near infrared light*

*source such as LEDs; neon; fluorescent, incandescent bulbs, lasers; flame sources; sunlight; etc*

- *Available in a wide range of resistance values*

### Applications

Photocells are used in many different types of circuits and applications.

#### Analog Applications

- *Camera Exposure Control*
- *Auto Slide Focus - dual cell*
- *Photocopy Machines - density of toner*
- *Colorimetric Test Equipment*
- *Densitometer*
- *Electronic Scales - dual cell*
- *Automatic Gain Control - modulated light source*
- *Automated Rear View Mirror*

#### Digital Applications

- *Automatic Headlight Dimmer*
- *Night Light Control*
- *Oil Burner Flame Out*
- *Street Light Control*
- *Absence / Presence (beam breaker)*
- *Position Sensor*

### Selecting a Photocell (Environmental/Circuitry Considerations)

#### Packaging

In order to be protected from potentially hostile environments photocells are encapsulated in either glass/metal (hermetic) package or are covered with a clear plastic coating. While the hermetic packages provide the greatest degree of protection, a plastic coating represents a lower cost approach. The disadvantage of plastic coatings is that they are not an absolute barrier to eventual penetration by moisture. This can have an adverse effect on cell life. However, plastic coated photocells have been used successfully for many years in such hostile environments as street light controls.

## Temperature Range

The chemistry of the photoconductive materials dictates an operating and storage temperature range of  $-40^{\circ}\text{C}$  to  $75^{\circ}\text{C}$ . It should be noted that operation of the cell above  $75^{\circ}\text{C}$  does not usually lead to catastrophic failure but the photoconductive surface may be damaged leading to irreversible changes in sensitivity. The amount of resistance change is a function of time as well as temperature. While changes of several hundred percent will occur in a matter of a few minutes at  $150^{\circ}\text{C}$ , it will take years at  $50^{\circ}\text{C}$  to produce that much change.

## Power Dissipation

During operation, a cell must remain within its maximum internal temperature rating of  $75^{\circ}\text{C}$ . Any applied power will raise the cell's temperature above ambient and must be considered.

Many low voltage situations involve very little power, so that the photocell can be small in size, where voltages and/or currents are higher, the photocell must be physically larger so that the semiconductor film can dissipate the heat. The curve of power dissipation versus ambient temperature describes the entire series of cells for operation in free air at room ambient ( $25^{\circ}\text{C}$ ). Note that regardless the size, all photocells de-rate linearly to zero at an ambient temperature of  $75^{\circ}\text{C}$ . The adequate heat sinks can increase the dissipation by as much as four times the levels shown in figure 4.

## Maximum Cell Voltage

At no time should the peak voltage of the cell exceed its maximum voltage. The designer should determine the maximum operating or peak voltage that the cell will experience in the circuit and choose an appropriately rated cell. Typical voltage rates range from 100V to 300V.

## Efficiency

The efficiency of photovoltaic systems is low compared with that of traditional thermal or hydroelectric plants. It may be over 20% sophisticated crystalline silicon systems and some 5% for some inexpensive thin film ones.

Practical photocells fail to reach the ideal efficiency owing to a number of loss mechanisms:

1. Some of the incident photons are reflected away from the cell instead of being absorbed or may be absorbed by obstructions such as current collecting electrodes.
2. Not all electron-hole pairs created live long enough to drift to the  $p-n$  junction. If their lifetime is small or if they are created too far from the junction, these pair will recombine and their energy is lost.
3. Carriers separated by the  $p-n$  junction will lose some of their energy while on the way to the output electrodes owing to the resistance of the connections. This constitutes the internal resistance of the cell.
4. Mismatch between photocell and load may hinder the full utilization of the generated power.

## Conclusions

Photovoltaic energy systems are often claimed to be the cleanest of all the renewable or non-renewable energy systems. In normal operation photovoltaic energy systems emit no gaseous or liquid pollutants, and no radioactive substances are involved. However, in case of Copper indium diselenide (CIS) Cadmium telluride (CdTe) modules, which contain small quantities of toxic substances, risk of release of these in atmosphere in case of a fire, if exist. A drawback of photovoltaic power generation is the intermittent and unreliable nature of insolation. To compensate, one needs either large storage systems or a source of backup

power. Both solutions substantially increase the required capital investment. A further disadvantage is

that load centers tend to be concentrated in regions where good insolation is unavailable.

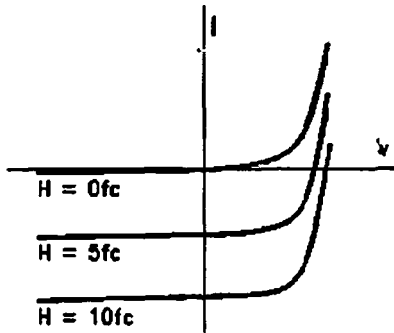

Figure : 1

Junction Photoconductor (Photodiode)

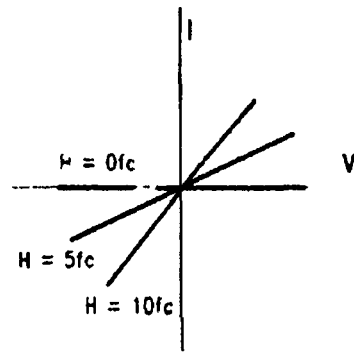

Figure : 2

Bulk Effect Photoconductor (Photocell)

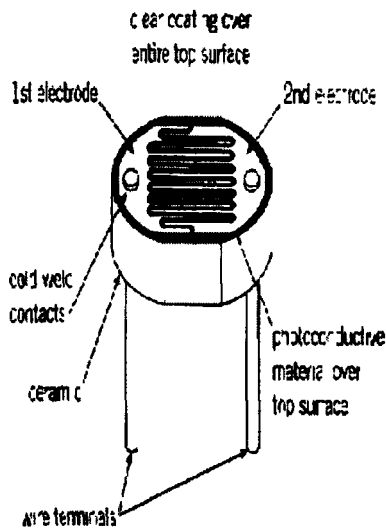

Figure : 3

Typical Construction of a Plastic Coated Photocell

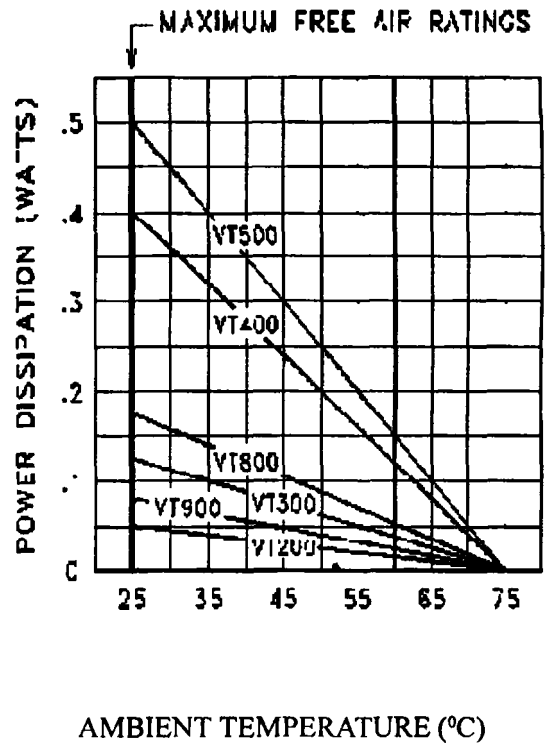
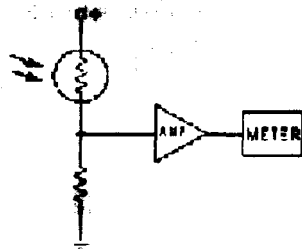

Figure : 4

The curve of power dissipation versus ambient temperature

# Photoconductive Cell Typical Application Circuits



## Ambient Light Measurement

Camera Exposure Meter (VT 900)  
Brightness Control (VT 900)

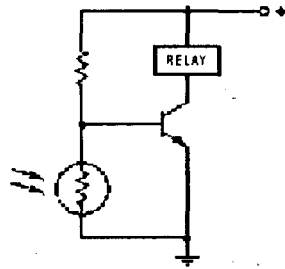

## DC Relay

Rear View Mirror Control (VT 200)  
Head Light Dimmer (VT 300 or VT 800)

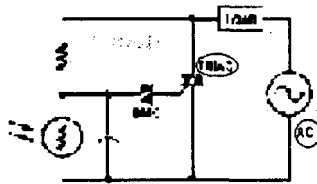

## AC Relay

Night Light Control (VT 800 or VT 900)  
Street Light Control (VT 400)  
Flame Detector (VT 400 or 500)

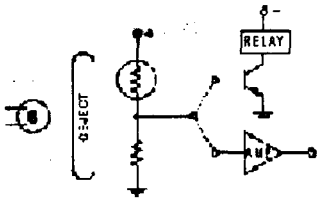

## Object Sensing / Measurement

Beam Breaking Applications (VT 800)  
Security Systems (VT 800 or VT 900)  
Colorimetric Test (VT 200 or VT 300)  
Densitometer (VT 200 or VT 300)

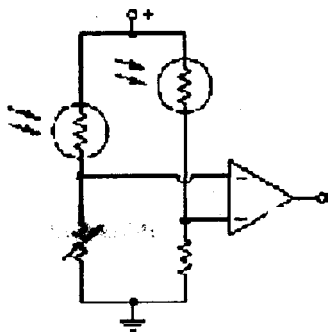

## Bridge Circuits

Auto Focus (VT 300 CT or VT 800 CT)  
Electronic Scales (VT 300 CT or VT 800 CT)  
Photoelectric Servo (VT 300 CT or VT 800 CT)